

Filterlüfter **LV 610**

Filter Fan



Technische Daten / Technical data:				
Type:	LV 610			
Spannung Voltage	230 V 50/60 Hz	115 V 50/60 Hz	48V DC	24 V DC
Stromaufnahme Amperage	0,29/0,35 A	0,58/0,70 A	1,3 A	2,6 A
Leistung Power input	64/80 W		55 W	
Drehzahl Speed	2550/2800 min ⁻¹		2950 min ⁻¹	
Temperaturbereich Temperature range	-10...+55 °C		-25...+60 °C	
Lebensdauer Service life	40.000 h			
Schallpegel Noise level	60 dB (A)			
Zulassung Approval	CE			
Farben colours	RAL 7035 (Standard), RAL 7032			
Schutzart Degree of protection	IP 54 mit Filtermatte G3 IP 54 with Filter mat G3			
	IP 55 mit Z-Line Filter (F5) und Streckmetall, UV-beständiges Frontgitter IP 55 with Z-Line Filter (F5) and expanded metal, UV-resistant front grille			
Luftfördermenge / Air flow: (m³/h)				
Filtermatte Filter mat	G3 50 Hz	G3 60 Hz	Z-Line-Filter 50 Hz	Z-Line-Filter 60 Hz
Luftleistung freiblasend Air flow free air	465	515	425	470
mit Austrittsfilter GV 600/700 with exhaust filter	325	355	297	325
mit 2 x GV 600/700 with 2 exhaust filter	372	422	328	372

Zubehör / **Accessories:**

Austrittsfilter / **Exhaust filter**

Dichtung / **gasket**

Ersatzfiltermatte / **Replacement filter mat**

Thermostate / **Thermostats**

GV 600/700

D 700

AM 735P, AM 700P, AM 700T, ZF 600/700

TRS 60, TRW 60, TWR 60, TKW 60

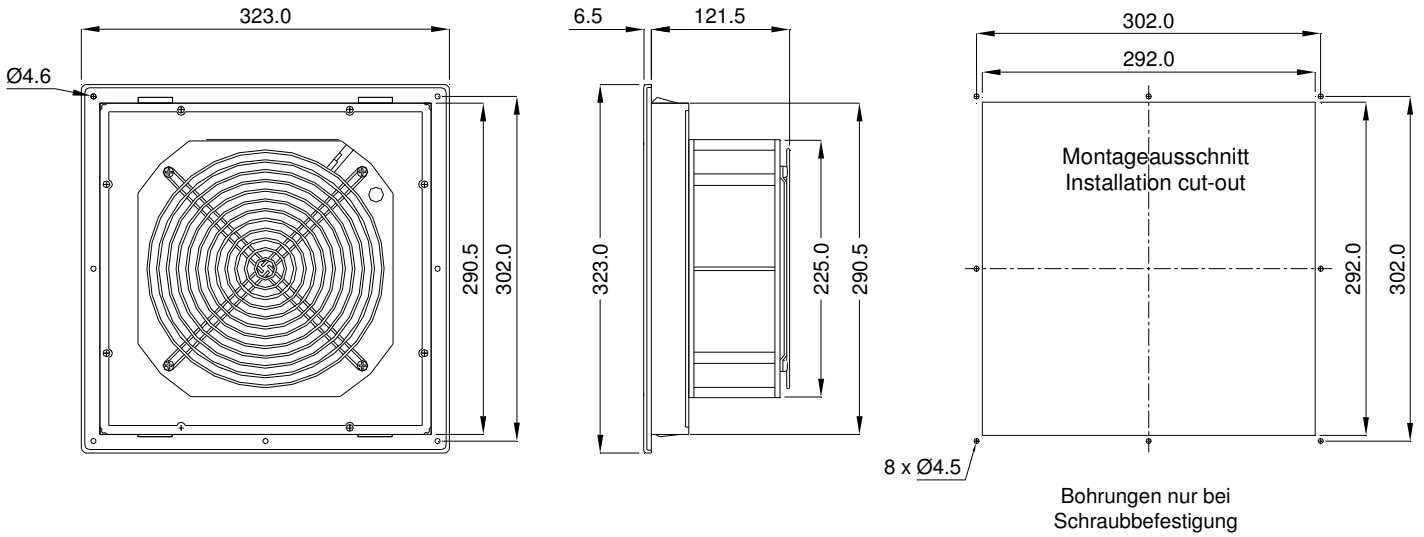

Bohrungen nur bei Schraubbefestigung
 Drill-holes are only necessary if fan is to be fastened with screws

Leistungsdiagramm
 Performance diagram

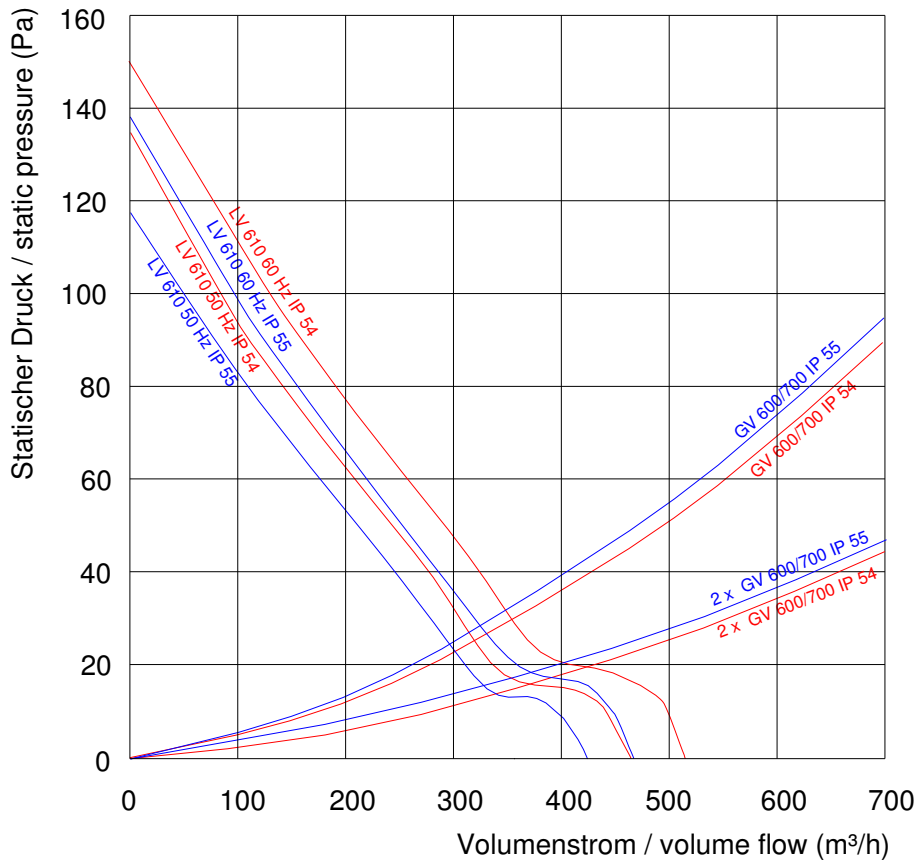

Rev. 04/10

